



M/DN[®] Tibial and Humeral Intramedullary Fixation

Surgical Technique



Surgical Techniques for Fixation of Fractures with M/DN Tibial and Humeral Nails

Table of Contents

Surgical Technique for M/DN Tibial Nails	2
Introduction	2
Indications	2
Preoperative Planning	3
Patient Positioning and Radiographic Control	3
Reduction	3
Incision and Exposure	3
Creating the Entry Portal	4
Guide Wire Placement and Reaming	4
Nail Insertion	7
Proximal Locking	9
End Cap Placement	12
Distal Locking	13
Technique for Using the Free-Hand Targeting Device	13
Closure and Postoperative Care	16
Extraction	16
Surgical Technique for M/DN Humeral Nails	17
Introduction	17
Indications	17
Preoperative Planning	18
Patient Positioning and Radiographic Control	18
Reduction	19
Incision and Exposure	19
Creating the Entry Portal	19
Guide Wire Placement and Reaming	19
Nail Insertion	22
Proximal Locking	24
End Cap Placement	25
Distal Locking	26
Technique for Using the Free-Hand Targeting Device	26
Closure and Postoperative Care	29
Extraction	29
Instrument Case Options	30

Surgical Technique for M/DN Tibial Nails

Introduction

The tibial interlocking nail uses the closed technique during insertion as well as the ability to lock the nail proximally and distally to resist axial forces and shortening of the tibia. *M/DN* Tibial Interlocking Nails range in diameters from 6mm to 15mm and lengths from 18cm to 46cm (Table 1).

Indications

The Tibial Nail is indicated for use in a variety of tibial fractures (Fig. 1), such as:

- A. Comminuted fractures
- B. Segmental fractures
- C. Fractures with bone loss
- D. Nonunions
- E. Proximal and distal fractures
- F. Transverse fractures
- G. Oblique fractures
- H. Spiral fractures
- I. Bilateral fractures
- J. Fractures with butterfly fragments
- K. Pseudoarthrosis of the tibial shaft
- L. Corrective Osteotomies

Table 1. Tibial Nail Implant Sizes

Nail Length (cm)	Nail Diameter (mm)										
	6	7	8	9	10	11	12	13	14	15	
18	•	•	•	•	•	•					
20	•	•	•	•	•	•	•				
22	•	•	•	•	•	•	•	•			
24	•	•	•	•	•	•	•	•	•	•	
26	•	•	•	•	•	•	•	•	•	•	•
28	•	•	•	•	•	•	•	•	•	•	•
30	•	•	•	•	•	•	•	•	•	•	•
32	•	•	•	•	•	•	•	•	•	•	•
34	•	•	•	•	•	•	•	•	•	•	•
36	•	•	•	•	•	•	•	•	•	•	•
38	•	•	•	•	•	•	•	•	•	•	•
40		•	•	•	•	•	•	•	•	•	•
42			•	•	•	•	•	•	•	•	•
44					•	•	•	•	•	•	•
46						•	•	•			

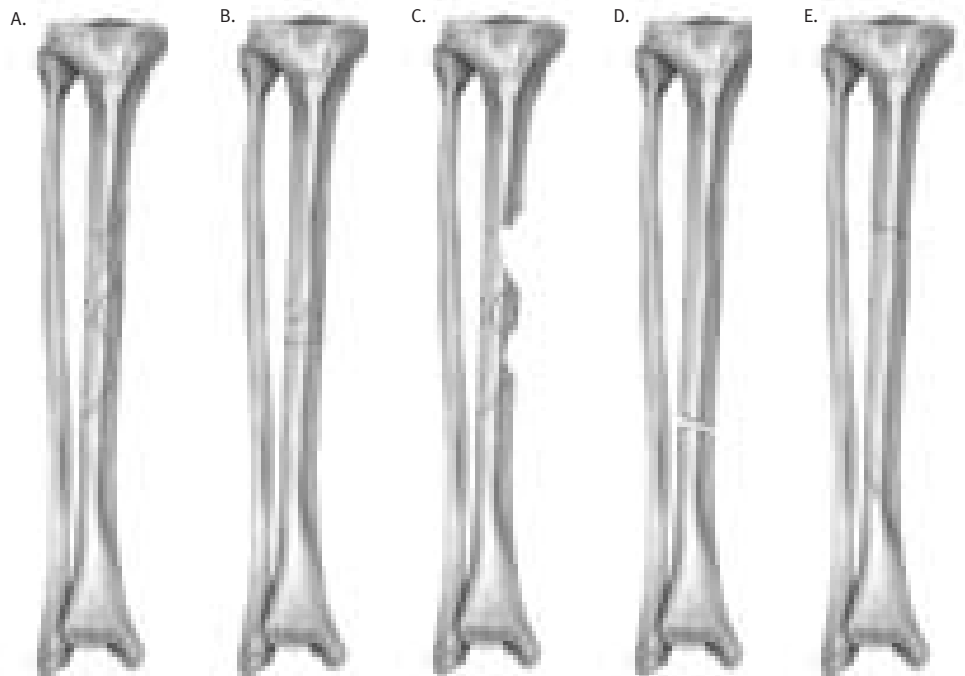

Fig 1

Comminuted fractures

Segmental fractures

Fractures with bone loss

Nonunions

Proximal and distal fractures

Preoperative Planning

Proper preoperative planning is essential to successful interlocked nailing of the tibia. A template or ossimeter, and an x-ray film of the unaffected extremity are necessary for determining canal size and for measuring the length of the tibia to aid in determining nail length.

The Nail Length Gauge or Harris/Galante Bulb-Tip (Sounds), available in diameters from 10mm-17mm, can also be used as alternate techniques to determine nail diameter and length.

X-rays taken at a 36-inch distance from the x-ray source result in 10-15 percent magnification of bone. The *M/DN* ossimeter has both an actual size scale and one that takes into account this magnification. It should be used routinely to determine nail diameter and length.

The proper length of the nail should extend from 1cm below the top of the tibia to the epiphyseal scar. The diameter of the tibial nail should match the canal in the lateral x-ray projection. The surgeon should review the x-ray to assure that there are no unusual anatomic variations.

Patient Positioning and Radiographic Control

Place the patient in the supine position on the fracture table with the injured extremity in traction and the legs extended. A small roll may be placed under the affected leg. Visualize the affected knee as well as the shaft of the tibia using image intensification to confirm proper positioning prior to prepping and draping.

An alternate method of positioning is to place a radiolucent frame under the knee, or to place the patient on a radiolucent table (Fig. 2), using a distractor for fracture reduction.



Fig. 2

Reduction

It is important to reduce the fracture before beginning the surgical procedure.

Incision and Exposure

Make a longitudinal incision along the medial border of the patellar ligament extending from the joint line to the inferior pole of the patella (Fig. 3). Carry the dissection medially to the patellar tendon down to the bone. Place a Blunt Retractor beneath the patellar ligament and retract the ligament laterally to expose the proximal tibia.

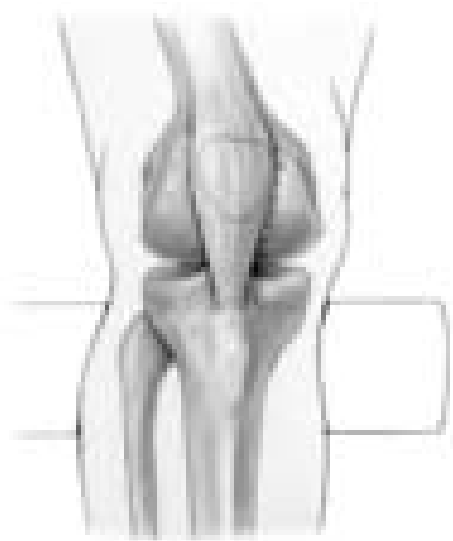

Fig. 3

Creating the Entry Portal

Place the Short T-Handle Cannulated Awl medial to the patellar tendon and at the top of the tibia (Fig. 4). For proximal fractures, either split the patellar tendon or position the awl lateral to the tendon to prevent angulation at the fracture site. Check the position with A/P and lateral views. When the correct position is achieved, rotate the awl to create an entry portal for the Ball-Tip Guide Wire (Fig. 5). The Ball-Tip Guide Wire may also be described as a Bulb-Tip or Bullet-Tip Guide Wire.

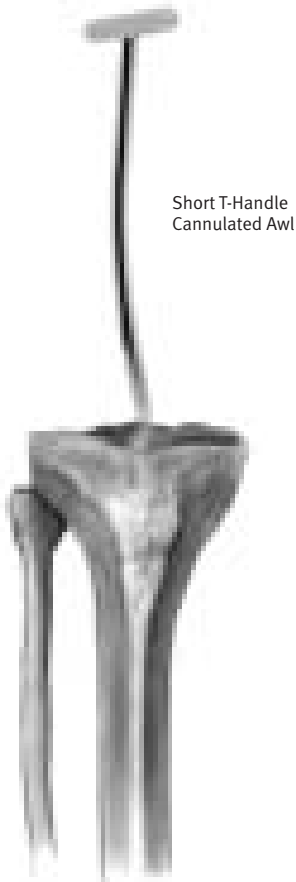

Fig. 4



Fig. 5

If using the Short Cannulated Awl, insert a Steinmann Pin at the desired entry point. Rotate the Awl over the Steinmann Pin. If the pin has the correct starting point, but is in the wrong axis, remove the pin and adjust orientation using the awl. Advance the awl once the correct axis has been determined. If the pin does not have the correct starting point location, remove the pin and start over. Then, exchange the Steinmann Pin for the 3.0mm Ball-Tip Guide Wire.

Guide Wire Placement and Reaming

Conventional Guide Wire/ Exchange Tube Technique

Attach the 3.0mm Ball-Tip Guide Wire to the Wire Grip T-Handle (Fig. 6) and tighten.



Fig. 6

To aid in manipulation, bend the tip of the guide wire at about a 10° angle 5cm from the end. Insert the guide wire through the entry hole and manipulate it down the proximal tibia. At the fracture site, manipulate the guide wire into the distal fragment under C-arm control (Fig. 7).

CAUTION: If the guide wire is bent shorter than 5cm from the end of the wire and/or more than 10 degrees it may be difficult to remove from the nail. If the wire becomes lodged inside the nail, utilize the WIRE GRIP T-HANDLE and mallet to remove the guide wire from the nail.

Once in the distal canal, pass the wire to its final position at the epiphyseal scar (Fig. 8). Remove the Wire Grip T-Handle. Determine the proper nail length by placing a second guide wire of equal length on the proximal tibia. The length of the wire that is not overlapping is the correct nail length required (Fig. 9). The 50cm ruler or ossimeter may be used for an accurate measurement.

Another way to measure the length is to use the C-arm to position the “0” mark on the metal ruler at the distal tibial epiphyseal scar. Then read the correct length at the proximal tibia directly from the metal ruler.



Fig. 7

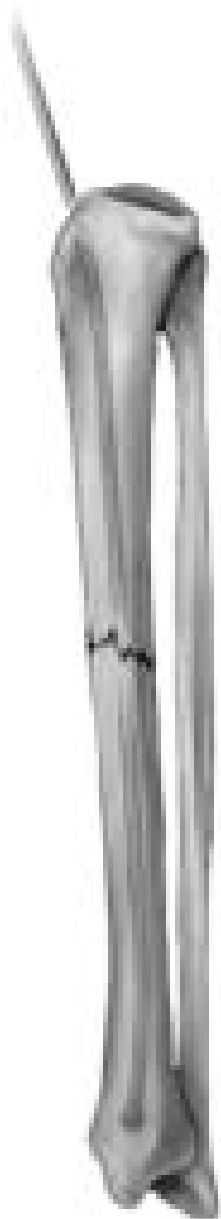

Fig. 8

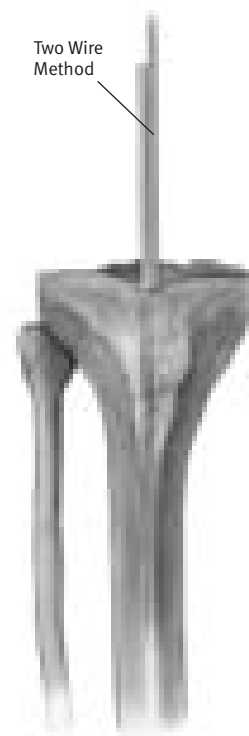

Fig. 9

Alternatively, the Nail Length Gauge can be used to measure the appropriate Nail length through the measurement of one 100cm guide wire. To use, place a 100cm Ball-Tip Guide Wire down the medullary canal. Slide the Nail Length Gauge over the Ball-Tip Guide Wire, ensuring that the distal portion of the gauge is resting on the proximal tibia in order to determine correct nail length. Nail length is determined by noting the location of the remaining Ball-Tip Guide Wire and reading the Nail Length Gauge at that particular location. If the length indicated is between two available nail sizes, it is recommended that the smaller nail be chosen.

NOTE: The Nail Length Gauge can only be used with 100cm Guide Wire.

Place an intramedullary reamer over the guide wire and ream the tibial canal in .5mm increments until contact is made with the cortical wall. The *Pressure Sentinel*® Intramedullary Reaming System is a system of one-piece reamers ranging in size from 5mm diameter to 27mm diameter in half millimeter increments. Each reamer is composed of a fluted reamer head, a shaft and a quick-connect drive end. The quick-connect end can be connected to a manual or powered driver. The width of the isthmus of the medullary canal is determined by preoperative x-ray examination. The instrument with the smallest possible diameter is used for initial reaming into the medullary canal. Reamers with a diameter of 5mm to 7.5mm use a 2.4 Ball-Tip Guide Wire while reamers with a diameter of 8mm to 27mm use a 3.0mm Ball-Tip Guide Wire. As reaming continues, the reamer size should be increased by 0.5mm or 1.0mm increments until an opening of the desired size is obtained (Fig. 10).

NOTE: To avoid reamer lodging during use, reaming should be immediately stopped and the reamers retracted when there is too much resistance. If the reamer becomes lodged, stop reaming immediately. Reverse the direction of rotation of the handpiece and back the reamer out of the canal. The reamer can also be extracted by snapping the T-Handle Extractor onto the reamer end and then gently tapping the extractor with a small mallet or hammer.

CAUTION: Excessive blows to the T-Handle Extractor may damage the reamer or the extractor.

During reaming, monitor the lateral view on the image intensifier to prevent excess reaming of the posterior cortex.

The proximal diameter of 6mm through 10mm nails is 11mm. Therefore, the tibia must be overreamed to 12mm (approximately 64mm in length). Nails 11mm in diameter and greater have proximal diameters equivalent to the shaft diameter.

NOTE: If the Guide Wire becomes lodged within the reamer, use the Wire-Grip T-Handle to push the Guide Wire back into the IM canal.

New Guide Wire Technique Option

If using a Ball-Tip Guide Wire that does NOT have a gold coated end OR if using a nail less than 10mm:

When the reaming is complete and the final measurements are made, insert the plastic Exchange Tube over the Ball-Tip Guide Wire. Remove the Ball-Tip Guide Wire and insert the Smooth Guide Wire (Fig. 11). **NOTE: 6mm and 7mm nails are solid and, therefore, the guide wire must be removed prior to nail insertion.**

If using a Ball-Tip Guide Wire that DOES have a gold coated end and if using a nail greater than 10mm:

The Ball-Tip Guide Wire can remain in place. It is **NOT NECESSARY** to exchange the Ball-Tip Guide Wire for a Smooth Guide Wire. **NOTE: 6mm and 7mm nails are solid and, therefore, the guide wire must be removed prior to nail insertion.**

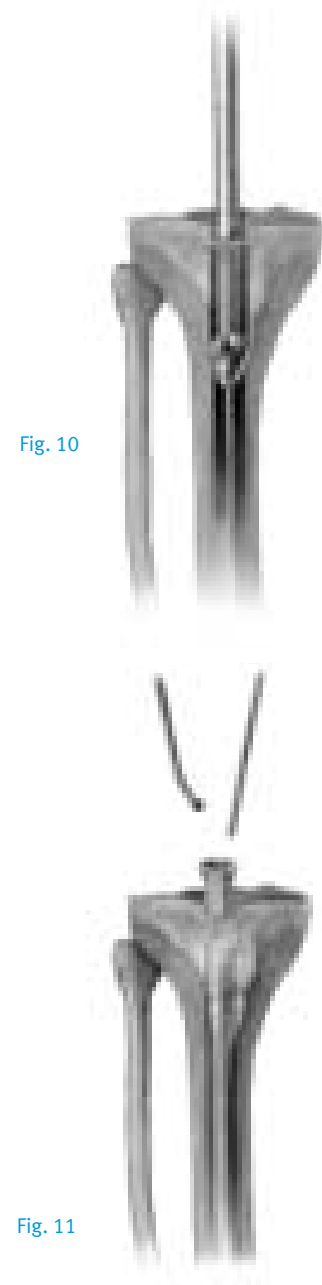

Fig. 10

Fig. 11

Nail Insertion

Attach the selected nail to the Tibial Proximal Guide. A keyway in the proximal end of the nail will help ensure proper alignment. Be sure the arrow on the proximal guide is pointing to the appropriate “Left” or “Right” indication (Fig. 12). Lift and turn the ratchet lever 90 degrees to open the ratchet mechanism of the Proximal Guide (Fig. 13).



Fig. 12

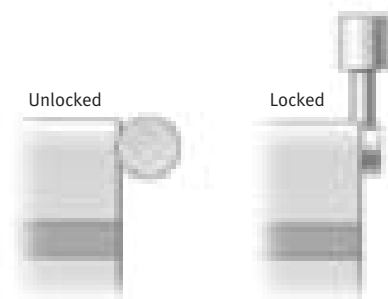

Fig. 13

Insert the Locking Bolt through the barrel of the guide (Fig. 14). Lift and turn the ratchet lever 90 degrees to close the ratchet mechanism, and use the Pin Wrench to tighten the Locking Bolt into the proximal end of the nail. The ratchet mechanism will prevent the bolt from loosening during insertion of the nail.

NOTE: If the ratchet mechanism of the Tibial Proximal Guide does not operate freely, it may be necessary to disassemble, clean, and reassemble the mechanism. If the ratchet mechanism becomes inoperative, it may be removed. The assembly will still function; however, the Locking Bolt may loosen during the procedure.

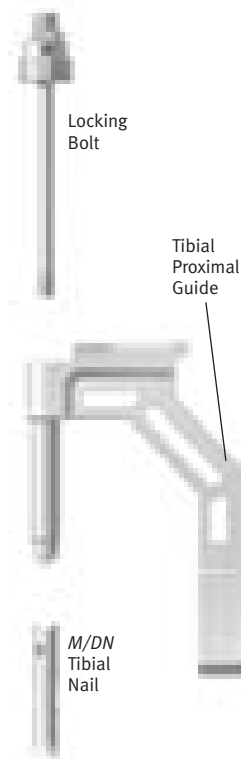

Fig. 14

Verify proper alignment by inserting the 8.0mm Tibial Screw Bushing, the 3.7mm Tibial/Humeral Drill Bushing, and the 3.7mm Drill (Table 2) into the appropriate hole of the Tibial Proximal Guide. When the device is properly aligned, the drill will pass through one of the proximal holes and will not contact the nail (Fig. 15).

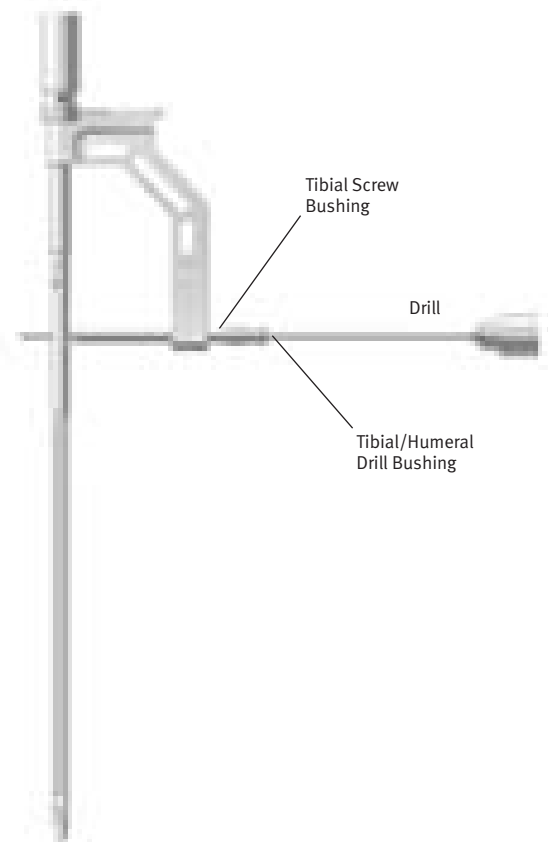

Fig. 15

Screw the Threaded Driver or Slaphammer into position on the Locking Bolt. Insert the nail over the Guide Wire and into the tibia. Begin seating the nail using gentle impaction with the Mallet. The nail must advance with each blow of the Mallet. If it does not, remove the nail and ream again. While impacting the nail, use the Tibial Proximal Guide to maintain the proper rotation.

The Slotted Mallet can be used with the Threaded Driver to make slight adjustments in depth (Fig. 16).

Be careful when crossing the fracture site. Visualize the fracture in two planes with image intensification to assure proper passage of the nail into the distal fragment (Fig. 17). The conical tip and the bevel of the nail will help guide it off the posterior cortex and maintain its position in the center of the canal (Fig. 18). Reduce the force of impaction as the proximal end of the nail approaches the tibial tubercle.

Prior to inserting the nail past the guide wire exit hole, **REMOVE THE GUIDE WIRE** so it does not get trapped in the bone. Finish seating the nail after the guide wire is removed.



Fig. 16

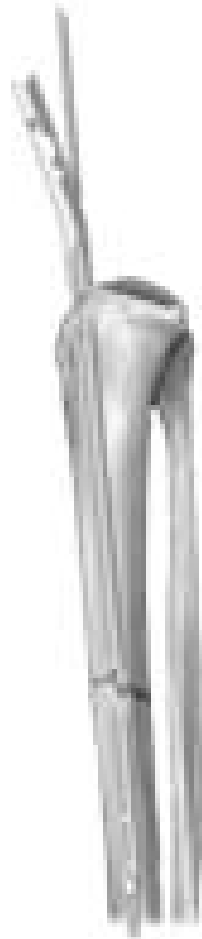

Fig. 17

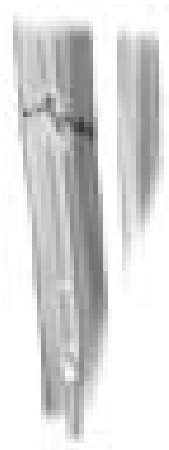

Fig. 18

The adapter has four holes. Two holes are for the left tibia, and two holes are for the right tibia. Use the two top holes. One hole is for anterolateral to posteromedial screw insertion. The other hole is for anteromedial to posterolateral screw insertion.

Insert the 8.0mm Tibial/Humeral Screw Bushing through the appropriate hole of the Tibial Proximal Guide or the Tibial Oblique Hole Adapter until contact is made with the skin. Insert the 3.7mm Tibial/Humeral Drill Bushing (Color Code: Blue), which screws into the Tibial/Humeral Screw Bushing.

Make a small stab wound, then advance the nested bushings through the incision until they contact the medial aspect of the bone (Fig. 20). Insert the 3.7mm Drill (Color Code: Blue).

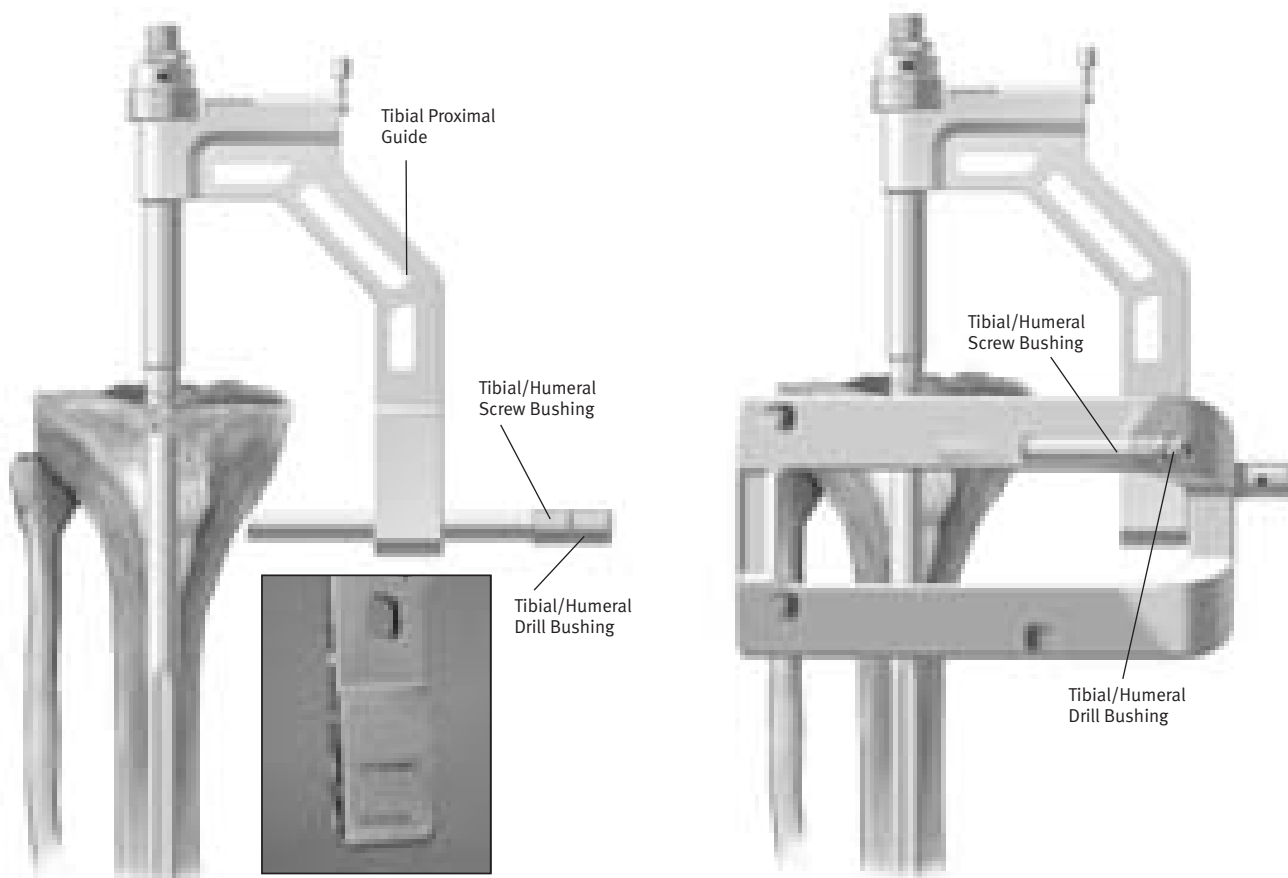

Fig. 20

Drill through both cortices (Fig. 21). The drill is calibrated to measure the hole depth and determine the appropriate screw length. If desired, the Proximal Screw Depth Gauge can also be used to determine the screw length (Fig. 22). Remove the drill and drill bushing.

The 4.2 or 4.5mm screw (Color Code: Blue) is used proximally on all tibial nails. **Select the appropriate screw length to ensure that the screw will engage the far cortex.**

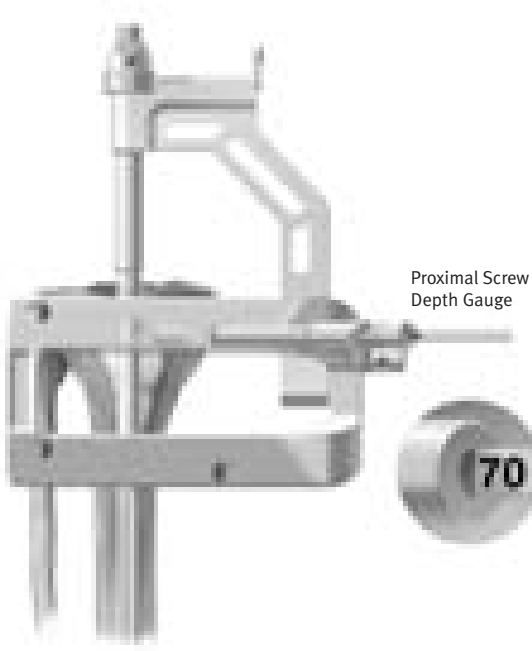
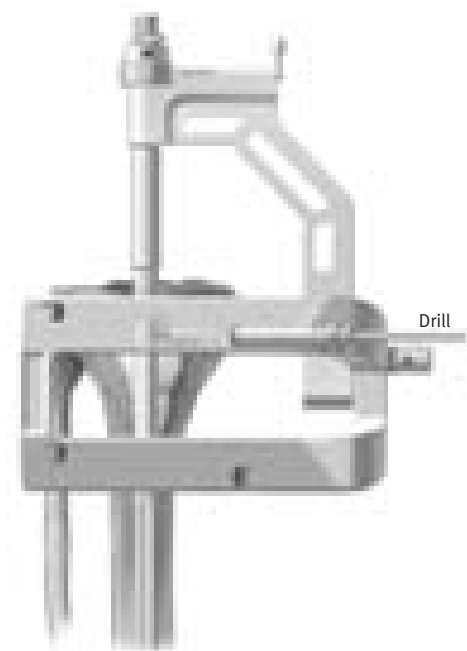
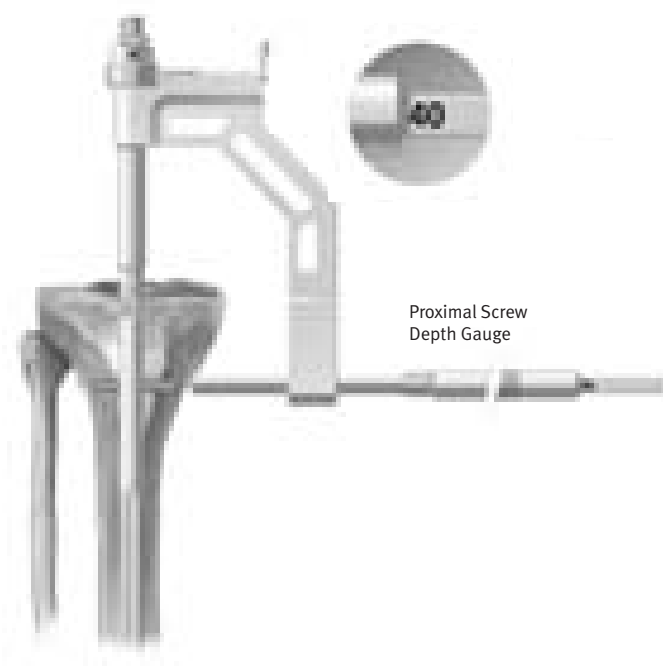
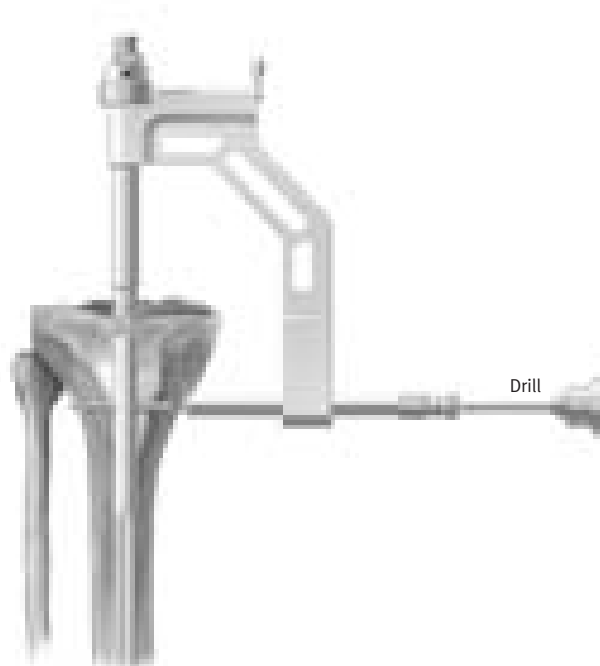

Fig. 21

Fig. 22

Use the T-Handle Screwdriver to insert the appropriate length 4.2 or 4.5mm screw until the reference line marked “Tib/Hum” is flush with the bushing (Fig. 23 & inset). Then use the C-arm to check the position of the screw and tighten it appropriately. Remove the T-Handle Screwdriver and Tibial/Humeral Screw Bushing.

If a second proximal screw will be used, repeat the procedure for the second screw.

Take A/P and lateral C-arm views to check for correct positioning. Disengage the ratchet mechanism, then loosen and remove the Locking Bolt and Tibial Proximal Guide.

NOTE: 4.2 or 4.5mm screws (Color Code: Blue) are used proximally for all Tibial Nails.

End Cap Placement

Insert an *M/DN* End Cap of the appropriate length (0mm, 5mm, 10mm, or 15mm) in the proximal nail. These caps help protect the internal threads of the nail, facilitate future extraction, and allow the surgeon to adjust the length of the nail.

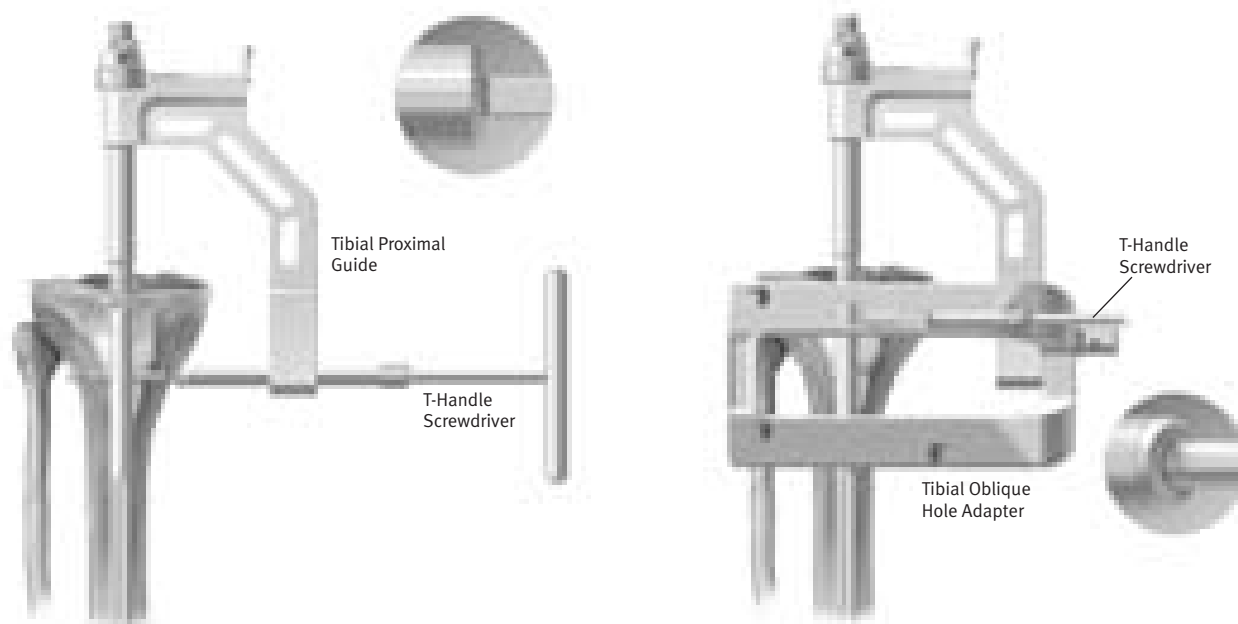

Fig. 23

Distal Locking

Technique for Using the Free-Hand Targeting Device

The distal locking screws are inserted with a free-hand technique using the Free-Hand Targeting Device. The *M/DN* Tibial Nail has three distal holes. Two are located for locking in the mediolateral plane, and one is located between the mediolateral holes for locking in the anteroposterior plane.

NOTE: 6mm tibial nails do not have locking holes distally. 7mm and 8mm nails use 3.7mm screws distally which require a 3.2mm Drill or Trocar (Color Code: Yellow). 9mm-15mm tibial nails use 4.2 or 4.5mm screws distally which require a 3.7mm Drill or Trocar (Color Code: Blue).



Fig. 24



Incorrect



Correct

Fig. 25

Insert the appropriate size Trocar into the Targeting Device and finger tighten (Fig. 24). It is very important to properly place the C-arm. Position the C-arm so the locking hole of the nail appears perfectly round on the monitor (Fig. 25).

Make a 1cm incision on the lower extremity over the appropriate locking hole. When using the anteroposterior hole, be careful to avoid the tendon of the tibialis anterior muscle. Insert the Trocar until it contacts the tibia. Use the C-arm view to center the tip of the Trocar over the locking hole (Fig. 26). Then use the C-arm to align the Trocar in the proper axis (Fig. 27). Use a small mallet to drive the Trocar into the tibia and through the hole in the nail in line with the x-ray beam. Do not penetrate the far cortex.

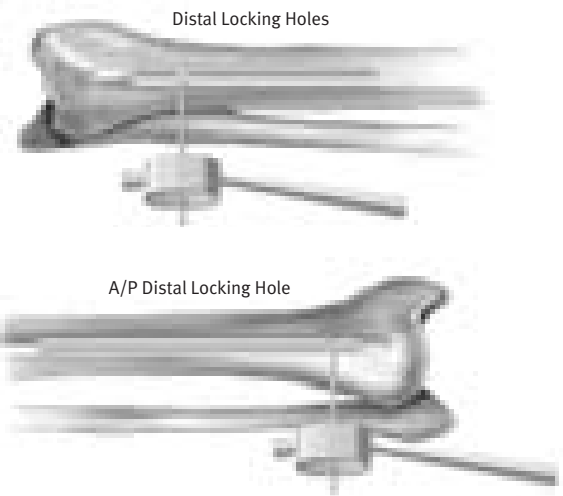
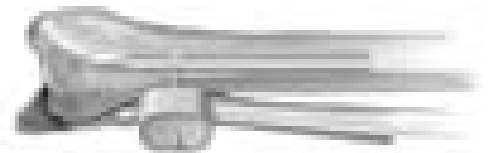

Fig. 26



Distal Locking Holes



A/P Distal Locking Hole

Fig. 27

Verify Trocar placement in both the A/P and lateral planes using image intensification (Fig. 28).

Remove the Trocar. The path of the Trocar in the bone acts as a pilot hole for the drill. Use the appropriate drill to drill a hole through the guide hole left by the Trocar (Fig. 29). Drill through the far cortex. Remove the drill.

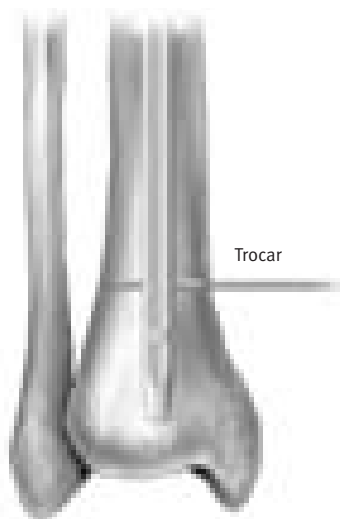

Fig. 28

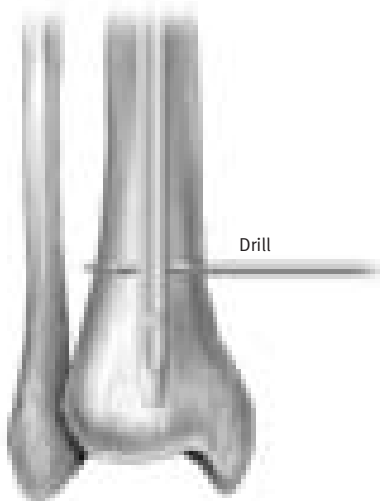

Fig. 29

Use the Distal Screw Depth Gauge to select the proper length screw (Fig 30). Read the length directly off the gauge. Select an appropriate length screw to ensure that the screw will engage the far cortex.

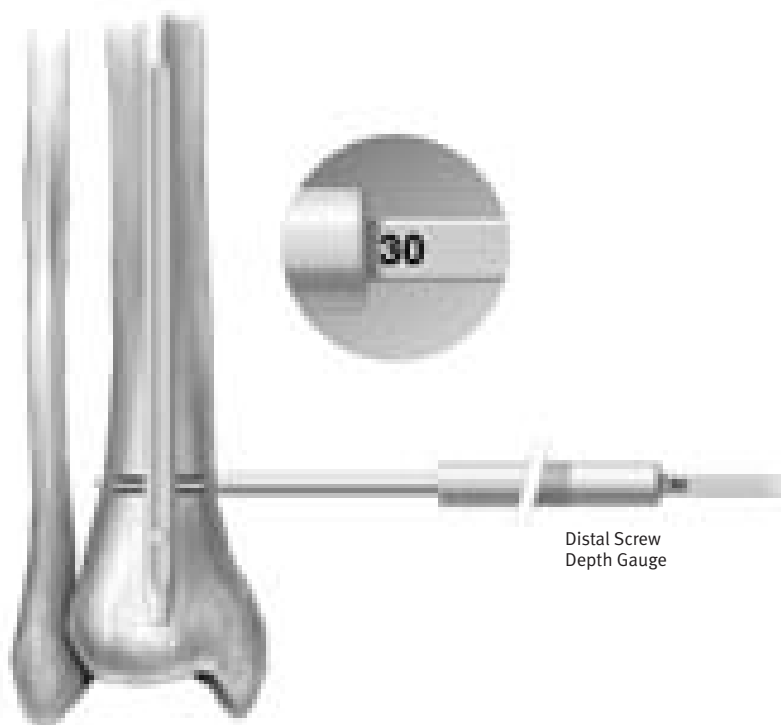

Fig. 30

Use the Distal Screwdriver to insert the screw through the hole (Fig. 31).

Insert the second and third distal locking screws in the same manner (Fig. 32). Check the position of all screws with the C-arm in the A/P and lateral planes (Fig. 33).

Bushings are available that can be used with the Free-Hand Targeting Device. A separate radiolucent Bushing Insert is available to accommodate the bushings.

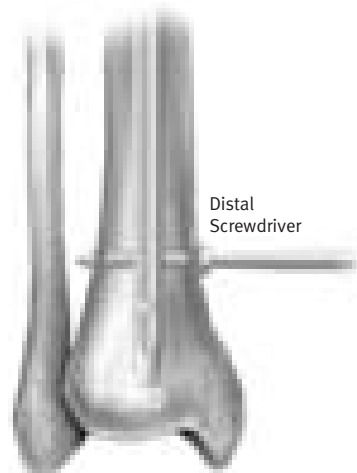

Fig. 31

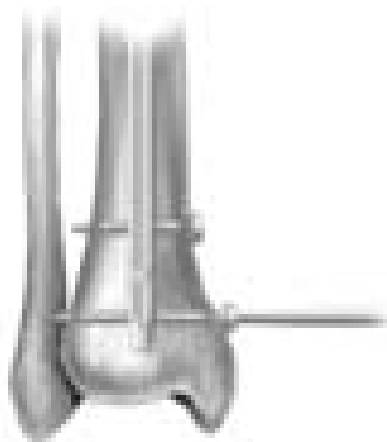

Fig. 32



Fig. 33

Closure and Postoperative Care

After irrigating the wounds, close the proximal wound in layers. Then apply a soft compression dressing.

A short leg splint is used until pain and swelling are decreased. Then early range-of-motion exercises of the knee and ankle are encouraged. Allow toe-touch weight bearing to progress to full weight bearing as fracture callus increases on x-ray films, usually six to eight weeks.

Extraction

Should extraction of the nail become necessary, attach the Threaded Extractor to the end of the nail and use the Slaphammer to extract the nail (Fig. 34).

The cannulated Locking Bolt should not be used for nail removal. Extraction of the nail should be accomplished by using the Threaded Extractor.

NOTE: Please refer to the package insert for complete product information, including contraindications, warnings, precautions, and adverse events.

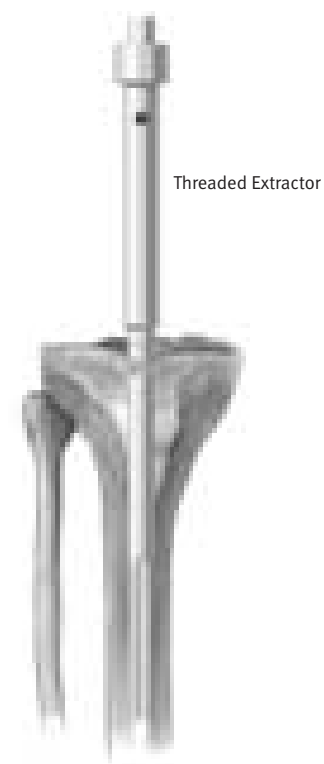

Fig. 34

Surgical Technique for M/DN Humeral Nail

Introduction

The humeral interlocking nail uses the closed technique during insertion as well as the ability to lock the nail proximally and distally. *M/DN* Humeral Interlocking Nails range in diameters from 6mm to 13mm and lengths from 18cm to 30cm. (Table 1)

Indications

The Humeral Nail is indicated for use in a variety of humeral fractures (Fig. 1), such as:

- A. Segmental fractures
- B. Comminuted fractures
- C. Fractures with bone loss
- D. Proximal and distal fractures
- E. Nonunions
- F. Delayed unions
- G. Pathological fractures
- H. Floating elbow
- I. Multiple trauma injuries
- J. Nerve lesion

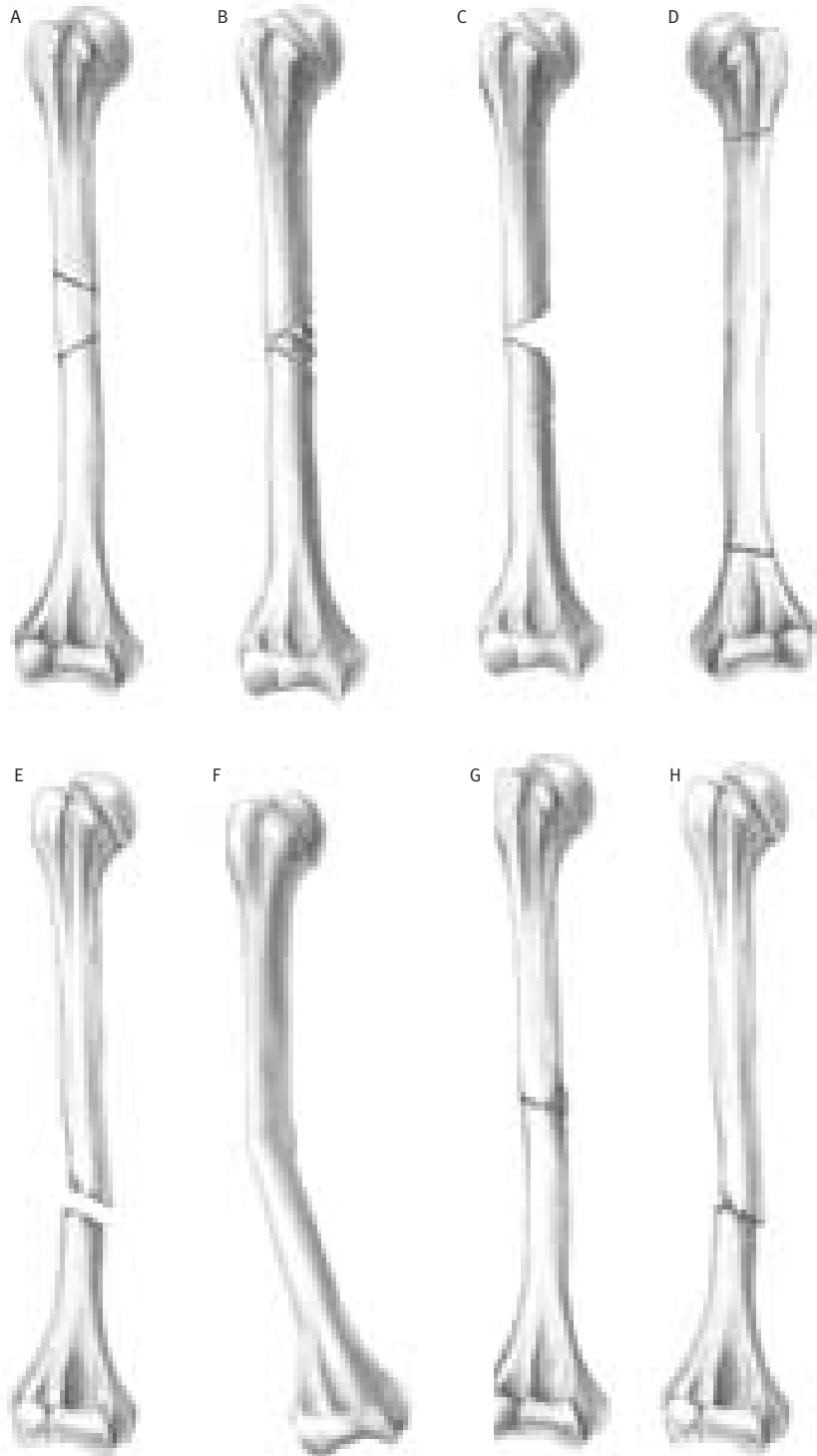

Table 1. Humeral Nail Expanded Set

Nail Length (cm)	Nail Diameter (mm)							
	6	7	8	9	10	11	12	13
18	•	•	•	•	•	•	•	•
19.5	•	•	•	•	•	•	•	•
21	•	•	•	•	•	•	•	•
22.5	•	•	•	•	•	•	•	•
24	•	•	•	•	•	•	•	•
25.5	•	•	•	•	•	•	•	•
27	•	•	•	•	•	•	•	•
28.5	•	•	•	•	•	•	•	•
30	•	•	•	•	•	•	•	•

Fig. 1

Preoperative Planning

Proper preoperative planning is essential to successful interlocked nailing of the humerus. A template or ossimeter and an x-ray film of the unaffected extremity are necessary for determining canal size at the isthmus and for measuring the length of the humerus to aid in determining nail length.

The Nail Length Gauge or the Harris/Galante Bulb-Tipped (Sounds), available in diameters from 10mm-17mm, can be used as an alternate techniques to determine nail diameter and length.

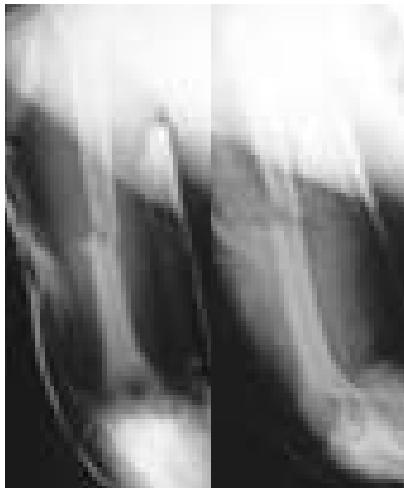

Fig. 2

X-rays taken at a 36-inch distance from the x-ray source result in 10-15 percent magnification of bone. The *M/DN* ossimeter has both an actual size scale and one that takes into account this magnification. It should be used routinely to determine nail diameter and length.

The proper length of the nail should extend from 5mm below the greater tuberosity to 2cm above the olecranon fossa. The diameter of the humeral nail should match the isthmus in the lateral x-ray to assure that there are no unusual anatomic variations.

Patient Positioning and Radiographic Control

Place the patient in the “beach chair” position with the operative shoulder slightly over the edge of the operative table (Fig. 2). The back should be angled at 45 degrees. Flex the patient at the hip with the foot lowered 20 degrees. Slide the patient to the side of the table so that the shoulder overhangs the table at the level of the scapula. Place a small sandbag beneath the shoulder for elevation.

Place the image intensifier above the arm so that, with the arm abducted, a clear anteroposterior and lateral view of the fracture can be obtained by rotating the image intensifier and the patient’s arm. The proximal humerus should also be visible on the image intensifier.

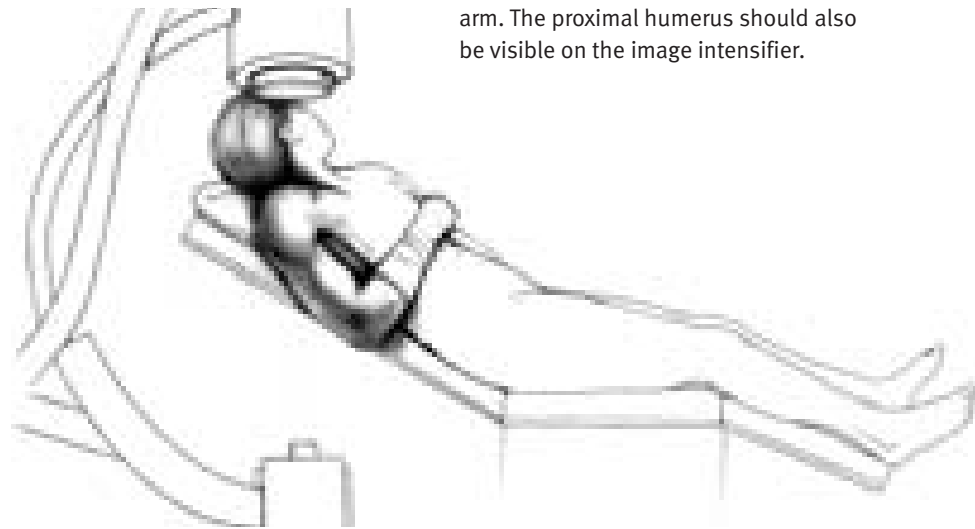

Reduction

It is important to reduce the fracture before beginning the surgical procedure.

Incision and Exposure

Begin the incision at the anterolateral aspect of the shoulder at the level of the acromion and extend it about 3cm distally (Fig. 3). Carry the dissection sharply down through the skin and subcutaneous tissue to the border of the acromion. Continue to the lateral aspect of the acromion in its anterior third.

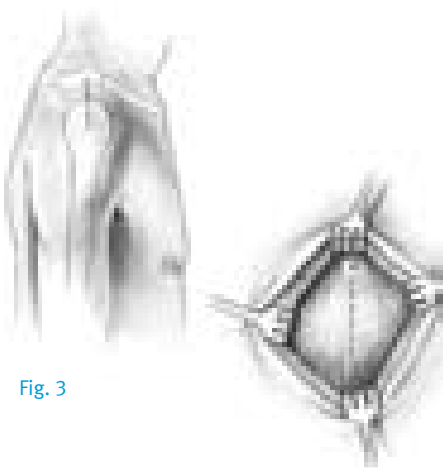

Fig. 3

Expose the edge of the acromion and split the deltoid. Adduct the arm across the chest to expose the greater tuberosity. Palpate the greater tuberosity and make an incision in the rotator cuff at the insertion of the rotator cuff into the greater tuberosity. Incise the rotator cuff longitudinally approximately 2cm. This should expose the superior aspect of the articular cartilage of the humerus and the insertion of the rotator cuff in the greater tuberosity.

Creating the Entry Portal

Place the Femoral or Tibial Awl at the junction of the articular cartilage and the greater tuberosity (Fig. 4). Check the position with A/P and lateral views. When the correct position is achieved, rotate the awl to create an entry portal for the Ball-Tip Guide Wire. The Ball-Tip Guide Wire may also be described as a Bulb-Tip or Bullet-Tip Guide Wire.

If using the short cannulated Awl, insert a Steinmann Pin at the desired entry point. Rotate the Awl over the Steinmann Pin. If the pin has the correct starting point, but is in the wrong axis, remove the pin and adjust orientation using the awl. Advance the awl once the correct axis has been determined. If the pin does not have the correct starting point location, remove the pin and start over.



Fig. 4

Guide Wire Placement and Reaming

Conventional Guide Wire/ Exchange Tube Technique

Attach the 3.0mm Ball-Tip Guide Wire to the Wire-Grip T-Handle (Fig. 5) and tighten. To aid in manipulation, bend the tip of the guide wire at about a 10°-15° angle 2cm from the end (or use a pre-bent guide wire). Insert the guide wire through the entry hole and manipulate it down the proximal humerus. Advance it to the edge of the proximal aspect of the fracture site and use the C-arm to assure proper placement.

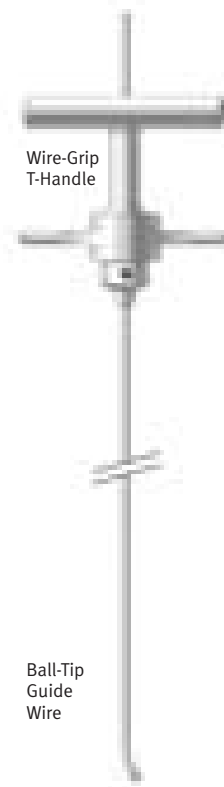

Fig. 5

Optional Technique: The 2.4mm Ball-Tip Guide Wire in 70cm length can be used as an alternative to the standard 3.0mm Ball-Tip Guide Wire (100cm length).

Position the arm to the side of the patient and place traction on the arm to align the humeral shaft. Manipulate the guide wire into the distal fragment under C-arm control (Fig. 6). Then advance the guide wire into the center of the epicondylar region of the humerus (Fig. 7). Remove the Wire-Grip T-Handle.

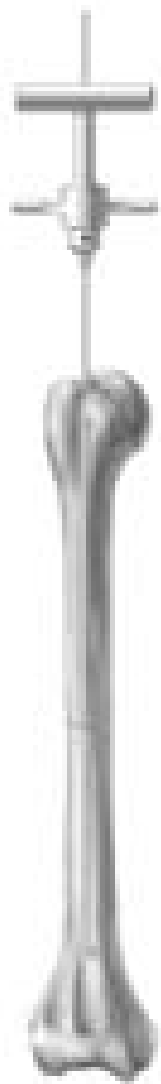

Fig. 6

Determine the proper nail length by placing a second guide wire of equal length at the point where the first guide wire enters the proximal humerus. The length of the wire that is not overlapping is the correct nail length required (Fig. 8). An alternative method is to place a clamp on the calibrated Ball-Tip Guide Wire at the point where the wire enters the proximal tibia and read the length from the calibration marks.

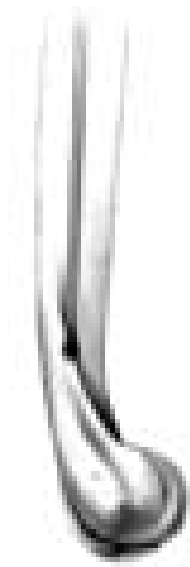

Fig. 7

Alternatively, the Nail Length Gauge can be used to measure the appropriate Nail length through measurement of one 100cm guide wire. To use, place a 100cm Guide Wire down the medullary canal. Slide the Nail Length Gauge over the Guide Wire, ensuring that the distal portion of the gauge is resting on the proximal humerus in order to determine correct nail length. Nail length is determined by noting the location of the remaining Guide Wire and reading the Nail Length Gauge at that particular location. If the length indicated is between two available nail sizes, it is recommended that the shorter nail be chosen.

NOTE: The 3.0mm Guide Wire must be used with the IM Nail Length Gauge.

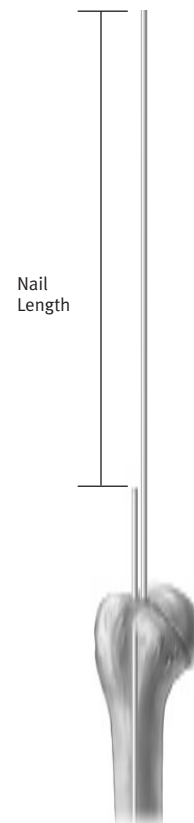

Fig. 8

Place an intramedullary reamer over the Ball-Tip Guide Wire and ream the humeral canal. Continue reaming in .5mm increments until contact is made with the cortical wall. Ream the humeral canal an additional 1mm larger. The diameter of the humeral nail selected should be 1mm less than the largest reamer used. Humeral nails from 6mm to 10mm have an 11mm proximal body. Overream to 12mm for these nails (approximately 50mm in length).

CAUTION: In a comminuted shaft fracture, do not ream across the area of comminution. Ream only in the solid aspect of the shaft. Avoid reaming when there is injury to the radial nerve.

The *Pressure Sentinel* Intramedullary Reaming System is a system of one-piece reamers ranging in size from 5mm diameter to 27mm diameter in half millimeter increments. Each reamer is composed of a fluted reamer head, a shaft and a quick-connect drive end. The quick-connect end can be connected to a manual or powered driver. The width of the isthmus of the medullary canal is determined by preoperative x-ray examination. The instrument with the

smallest possible diameter is used for initial reaming into the medullary canal. Reamers with a diameter of 5mm to 7.5 mm use a 2.4 Ball-Tip Guide Wire while reamers with a diameter of 8mm to 27mm use a 3.0mm Ball-Tip Guide Wire. As reaming continues, the reamer size should be increased by 0.5mm or 1.0mm increments until an opening of the desired size is obtained.

NOTE: To avoid reamer lodging during use, reaming should be immediately stopped and the reamers retracted when there is too much resistance. If the reamer becomes lodged, stop reaming immediately. Reverse the direction of rotation of the handpiece and back the reamer out of the canal. The reamer can also be extracted by snapping the T-Handle Extractor onto the reamer end and then gently tapping the extractor with a small mallet or hammer.

CAUTION: Excessive blows to the T-Handle Extractor may damage the reamer or the extractor.

NOTE: 6mm and 7mm nails are solid and, therefore, the guide wire must be removed before nail insertion. You must use a 2.4mm Guide Wire with all Humeral Nails.

New Guide Wire Technique Option

If using a Ball-Tip Guide Wire that does NOT have a gold coated end OR if using a nail less than 10mm:

When the reaming is complete and the final measurements are made, insert the plastic Exchange Tube over the Ball-Tip Guide Wire. Remove the Ball-Tip Guide Wire and insert the 2.4mm Humeral Smooth Guide Wire (Fig. 9).

If using a Ball-Tip Guide Wire that DOES have a gold coated end and if using a nail equal to or greater than 10mm:

The Ball-Tip Guide Wire can remain in place. It is **NOT NECESSARY** to exchange the Ball-Tip Guide Wire for a Smooth Guide Wire.

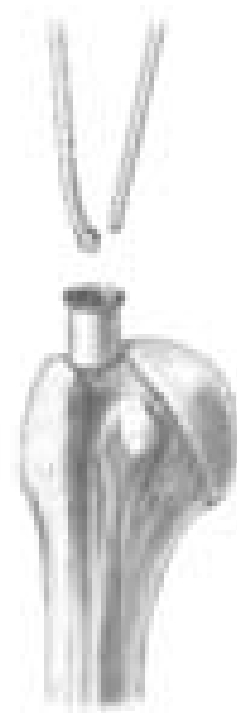

Fig. 9

Nail Insertion

Attach the selected nail to the Humeral Proximal Guide, making sure that the arrows align. A keyway in the proximal end of the nail will help ensure proper alignment (Fig. 10). Lift and turn the ratchet lever 90 degrees to open the ratchet mechanism of the Humeral Proximal Guide. Insert the Locking Bolt through the barrel of the guide (Fig. 11). Lift and turn the ratchet lever 90 degrees to close the ratchet mechanism, and use the Pin Wrench to tighten the Locking Bolt into the proximal end of the nail. The ratchet mechanism will prevent the bolt from loosening during insertion of the nail.

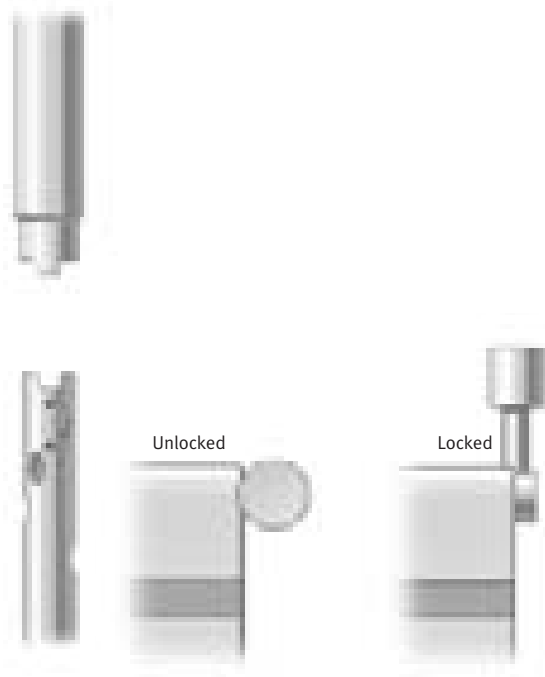

Fig. 10

NOTE: If the ratchet mechanism of the Humeral Proximal Guide does not operate freely, it may be necessary to disassemble, clean, and reassemble the mechanism. If the ratchet mechanism becomes inoperative, it may be removed. The assembly will still function; however, the Locking Bolt may loosen during the procedure.

NOTE: All humeral nails use 4.2 or 4.5mm screws proximally which require a 3.7mm Drill (Color Code: Blue).

Verify proper alignment by inserting the 8.0mm Tibial/Humeral Screw Bushing, the 3.7mm Tibial/Humeral Drill Bushing (Color Code: Blue), and the 3.7mm Drill (Color Code: Blue) (Table 2) into the appropriate hole of the Humeral Proximal Guide. When the device is properly aligned, the drill will pass through one of the proximal holes and will not contact the nail.

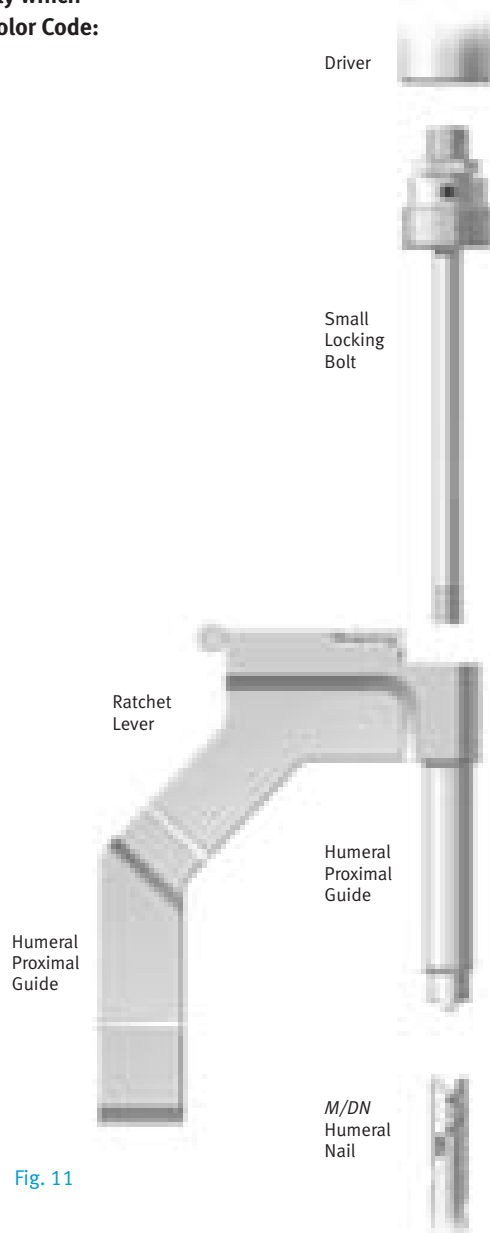

Fig. 11

Screw the Threaded Driver or Slaphammer into position on the Locking Bolt. Insert the nail over the 2.4mm Guide Wire and into the humerus. Begin seating the nail using gentle impaction with the mallet. The nail must advance with each blow of the mallet. If it does not, remove the nail and ream again. While impacting the nail, use the Humeral Proximal Guide to maintain the proper rotation.

The Slotted Mallet can also be used with the Threaded Driver to make slight adjustments in depth (Fig. 12).

Be careful when crossing the fracture site. Visualize the fracture in two planes with image intensification to assure proper passage of the nail into the distal fragment (Fig. 13).

Reduce the force of impaction as the proximal end of the nail approaches the humeral head. Nail should be inserted 5mm below subchondral bone.

When the nail is fully seated, **REMOVE THE GUIDE WIRE** so it does not get trapped in the bone. Remember, it might be concealed inside the driver or Slaphammer.



Fig. 12



Fig. 13

Table 2. Implant/Instrumentation Specifications for Humeral Nails

Nail Diameter (mm)	6	7	8	9	10	11	12	13
Head Diameter (mm)	11	11	11	11	11	11	12	13
Guide Wire, Smooth (mm)	—	—	2.4	2.4	2.4	2.4	2.4	2.4
Proximal Screw Size (mm)	4.2/4.5 blue	4.2/4.5 blue	4.2/4.5 blue	4.2/4.5 blue	4.2/4.5 blue	4.2/4.5 blue	4.2/4.5 blue	4.2/4.5 blue
Drill Bushing Size (mm)	3.7	3.7	3.7	3.7	3.7	3.7	3.7	3.7
Proximal Drill Size (mm)	3.7	3.7	3.7	3.7	3.7	3.7	3.7	3.7
Distal Screw Size (mm)	no holes	3.7 yellow	3.7 yellow	4.2/4.5 blue	4.2/4.5 blue	4.2/4.5 blue	4.2/4.5 blue	4.2/4.5 blue
Trocar Diameter (mm)	—	3.2	3.2	3.7	3.7	3.7	3.7	3.7
Distal Drill Size (mm)	—	3.2	3.2	3.7	3.7	3.7	3.7	3.7

Proximal Locking

The M/DN Humeral Nail has three oblique locking holes proximally.

Insert the Tibial/Humeral Screw Bushing through the hole of the Humeral Proximal Guide until contact is made with the skin. Insert the 3.7mm Tibial/Humeral Drill Bushing (Color Code: Blue), which screws into the screw bushing. Make a small stab wound, then advance the nested bushings through the incision until they contact the bone (Fig. 14). Insert the 3.7mm Drill (Color Code: Blue). Drill through both cortices (Fig. 15). The drill is calibrated to measure the hole depth and determine the appropriate screw length. If desired, the Proximal Screw Depth Gauge can also be used to determine the screw length (Fig. 16).

Select an appropriate length screw to ensure that the screw will engage the far cortex. Remove the drill and drill bushing.

Use the T-Handle Screwdriver to insert the appropriate 4.2 or 4.5mm screw (Color Code: Blue) to the correct hash mark (Fig. 17). Insert the screw until the “Tib/Hum” reference line is flush with the bushing. **Be careful not to drive the head of the screw through the lateral aspect of the humerus.** Remove the T-Handle Screwdriver and Tibial/Humeral Screw Bushing.

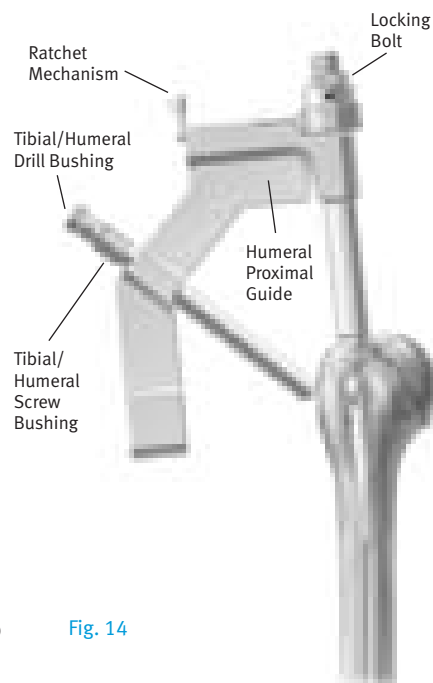

Fig. 14

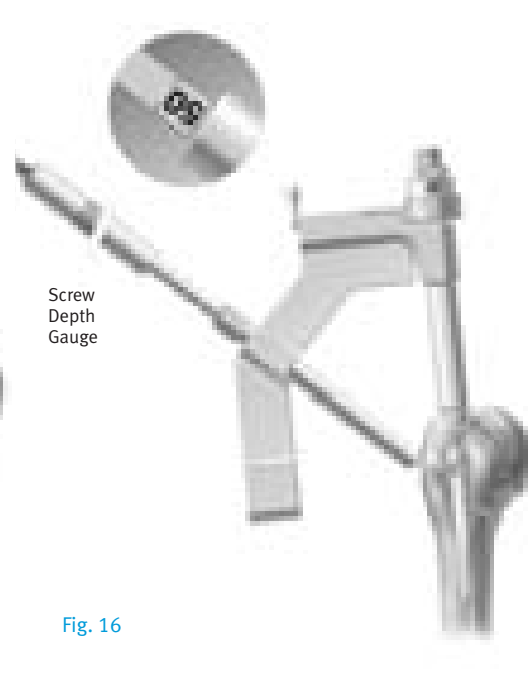

Fig. 16

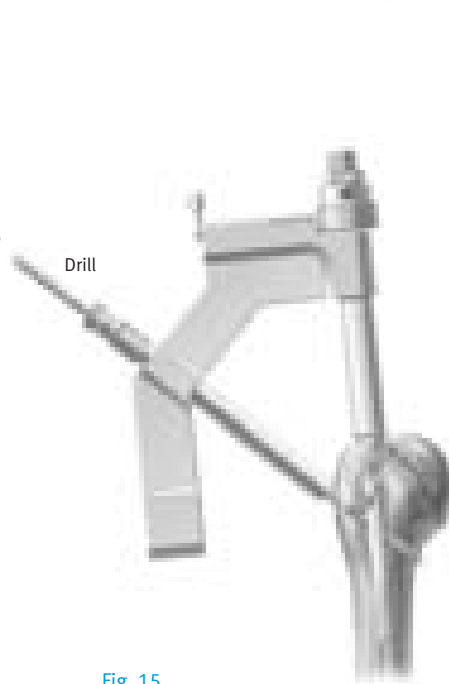

Fig. 15

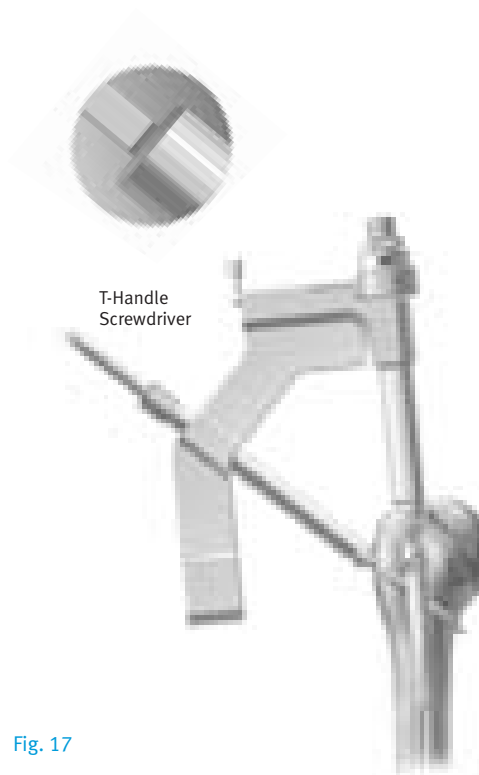

Fig. 17

For more proximal fractures, additional oblique screws may be used. Attach the Humeral Oblique Hole Adapter to the Humeral Proximal Guide (Fig. 18). Secure the adapter with a set screw, and tighten the screw with the Pin Wrench. The adapter has two holes. One hole is for anterolateral to posteromedial screw insertion. The other hole is for posterolateral to anteromedial screw insertion.

Insert the 8.0mm Tibial/Humeral Screw Bushing through the appropriate hole of the Humeral Oblique Hole Adapter until contact is made with the skin. Insert the 3.7mm Drill (Color Code: Blue). Drill through both cortices (Fig. 19). Determine the screw length by using the calibrations on the drill.

Select a screw 5mm shorter than measured to avoid penetration of the head. Remove the drill and drill bushing.

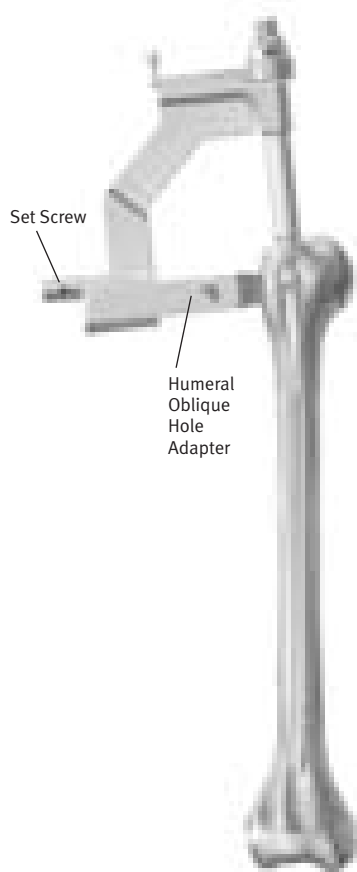

Fig. 18

Use the T-Handle Screwdriver to insert the appropriate length 4.2 or 4.5mm screw (Color Code: Blue) until the reference line marked “Tib/Hum” is flush with the bushing (Fig. 20). Then use the C-arm to check the position of the screw and tighten it appropriately. Remove the T-Handle Screwdriver and Tibial/Humeral Screw Bushing.

If an additional proximal screw will be used, repeat the procedure.

Take A/P and lateral C-arm views to check for correct positioning. Disengage the ratchet mechanism, then loosen and remove the Locking Bolt and Humeral Proximal Guide.

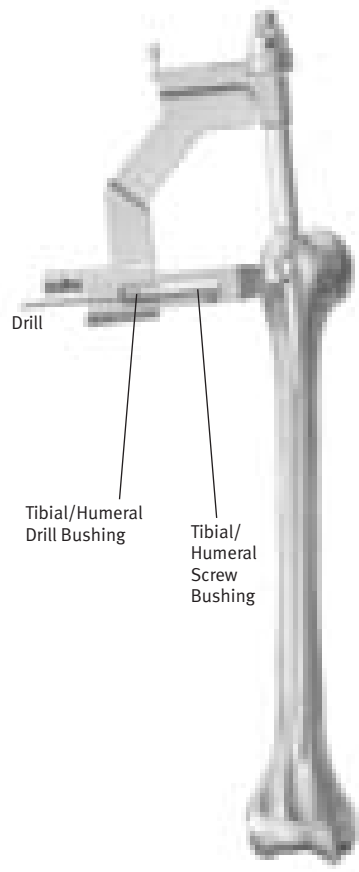

Fig. 19

Be sure that the humerus has not been distracted during nail insertion and proximal locking. Before locking the nail distally, tap on the elbow or the insertion device to ensure impaction.

The proximal portion of the M/DN Humeral Nail also has three suture holes which allow the use of 1.3mm Cable-Ready® Cable with needle or suture wire to capture humeral head fragments and the rotator cuff.

NOTE: 4.2 or 4.5mm screws (Color Code: Blue) are used proximally for all Humeral Nails.

End Cap Placement

Insert the Humeral Locking Nail Cap to ensure secure fixation with the proximal oblique screw.

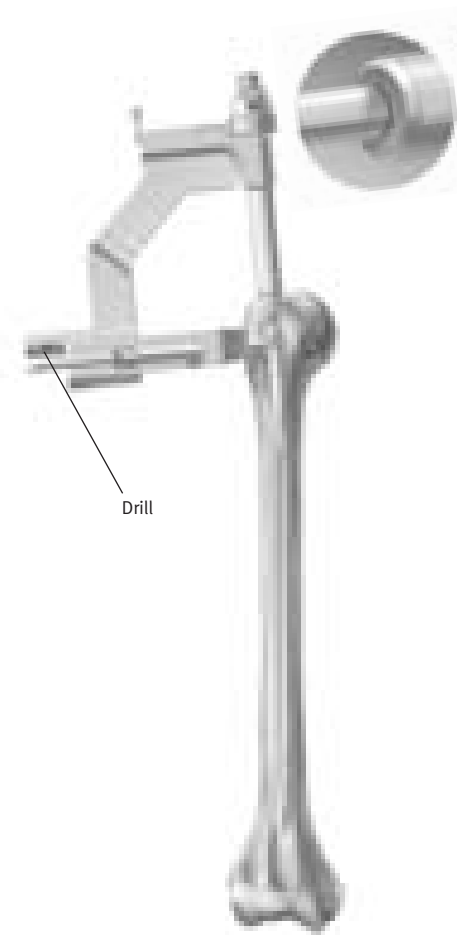

Fig. 20

Distal Locking

Technique for Using the Free-Hand Targeting Device

The distal locking screws are inserted with a free-hand technique using the Free-Hand Targeting Device. The inferior distal hole of the *M/DN* Humeral Nail is an anteroposterior dynamic slot to help achieve dynamization. The second hole is for static locking. If static locking is preferred, but there is a potential need for later dynamization, insert screws in both anteroposterior locking holes. The locking screw in the static hole can then be removed to achieve later dynamization.

NOTE: 6mm nails are not locked distally. 7mm and 8mm nails use 3.7mm screws distally which require a 3.2mm Drill or Trocar (Color Code: Yellow). 9mm-13mm nails use 4.2 or 4.5mm screws distally which require a 3.7mm Drill or Trocar (Color Code: Blue).

Insert the appropriate Trocar into the Targeting Device and finger tighten (Fig. 21).

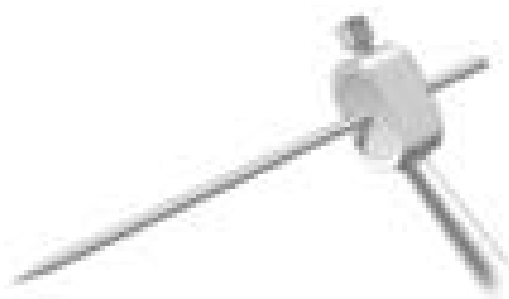

Fig. 21

It is very important to properly place the C-arm. When using the distal static hole, position the C-arm so the locking hole of the nail appears perfectly round on the monitor (Fig. 22). When using the distal dynamic slot, position the C-arm so the slot appears in such a way that reveals its greatest width.

Make a 2cm incision over the appropriate locking hole. Insert the Trocar until it contacts the humerus. Use the C-arm view to center the tip of the Trocar over the locking hole (Fig. 23). Then use the C-arm to align the Trocar in the proper axis (Fig. 24). Use a small mallet to drive the Trocar into the humerus and through the hole in the nail in line with the x-ray beam. Do not penetrate the opposite cortex.



Incorrect



Correct

Fig. 22



Fig. 23

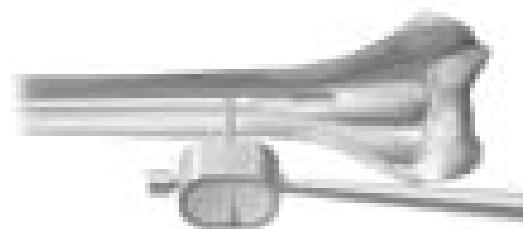

Fig. 24

Verify Trocar placement in both the A/P and lateral planes using image intensification (Fig. 25). Remove the Trocar. The path of the Trocar in the bone acts as a pilot hole for the drill. Use the appropriate drill to drill a hole through the guide hole left by the Trocar (Fig. 26). Drill through the near cortex. Remove the power drill, leaving the drill bit in the bone. Use image intensification to be sure that the drill is through the inferior aspect of the dynamic slot. Then advance the drill through the posterior cortex.

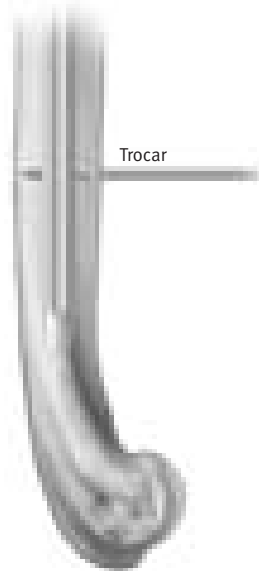

Fig. 25

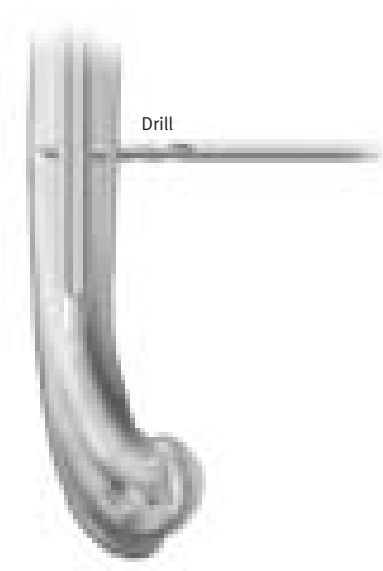

Fig. 26

Use the Distal Screw Depth Gauge to select the proper length screw (Fig. 27). Read the length directly off the gauge. Select an appropriate length screw to ensure the screw engages the far cortex. Use the Distal Screwdriver to insert the appropriate screw (Fig. 28). Then check the position of the screw in the anteroposterior and lateral planes.

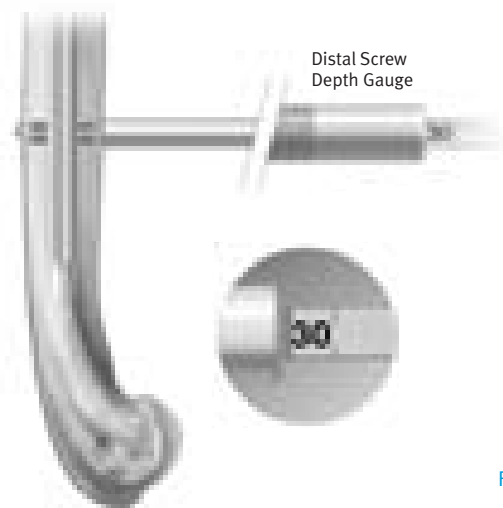

Fig. 27

Insert the second distal locking screw in the same manner (Fig.29). Check the position of both screws with the C-arm in the A/P and lateral planes.

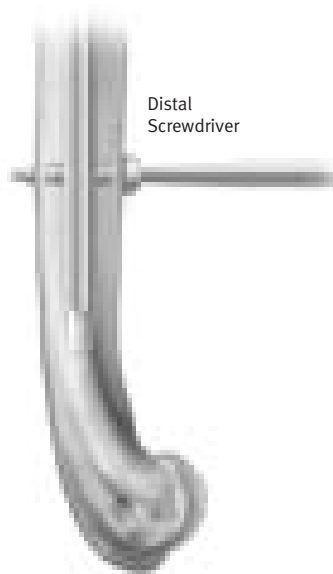

Fig. 28

Bushings are available that can also be used with the Free-Hand Targeting Device. A separate radiolucent Bushing Insert is available to accommodate the bushings.



Fig. 29

Closure and Postoperative Care

After irrigating the wounds, close the rotator cuff with tendon sutures after debridement of frayed edges. Close the subcutaneous tissue and skin in a routine fashion and apply a soft, sterile compression dressing. Early range of motion of the shoulder and elbow is encouraged if stable fixation is achieved.

Extraction

Should extraction of the nail become necessary, attach the Threaded Extractor to the end of the nail and use the Slaphammer to extract the nail after all interlocking screws have been removed (Fig. 30).

The Cannulated locking bolt should not be used for nail removal. Extraction of the nail should be accomplished by using the Threaded Extractor.

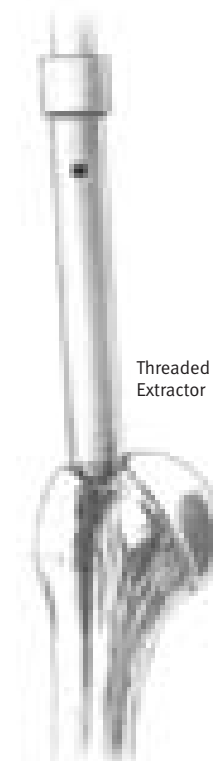

Fig. 30

Instrument Case Options

M/DN Instruments (Metal Femoral/Tibial/Humeral/Retrograde)

Set Number 00-2255-000-18 (includes case/tray/lid + instruments)
Case Set Number 00-2237-068-00 (includes trays and lid)

Metal Femoral Guides/Instruments (top tray holds the following)

Prod. No.	Description	
00-2255-001-03	Locking Bolt Assembly	2
00-2255-002-10	Fem. Prox. Targeting Guide	1
00-2255-002-11	Fem. Prox. Targeting Guide	1
00-2255-004-32	3.2mm Pin Bushing	2
00-2255-004-50	5.0mm Drill Bushing	2
00-2255-004-80	8.0mm Screw Bushing	2
00-2255-011-00	Recon Screw Counterbore	1
00-2258-067-00	<i>ITST</i> ® Threaded Guide Pin 355mm	3
00-2255-028-00	Pin Wrench	1
00-2255-035-50	5.0mm Femoral Drill, Large	3

Tibial/Humeral Instruments (middle tray holds the following)

Prod. No.	Description	
00-2255-001-00	Locking Bolt	2
00-2255-003-00	Tibial Proximal Targeting Guide	1
00-2255-003-01	Tibial Oblique Hole Adapter	1
00-2255-003-03	Set Screw	2
00-2255-004-00	Humeral Proximal Targeting Guide	1
00-2255-004-01	Humeral Oblique Hole Adapter	1
00-2255-036-37	Tib./Hum. 3.7mm Drill Bushing	2
00-2255-036-80	Tib./Hum. 8.0mm Screw Bushing	2
00-2255-028-00	Pin Wrench	1
00-2255-032-37	Tib./Hum. 3.7mm Drill	2

Retrograde Femoral Instruments (base of case holds the following)

Prod. No.	Description	
00-2241-001-00	Retro. Targ. Guide Assembly (4 pcs.)	1
00-2241-001-01	Adj. Targ. Arm Assembly (5 pcs.)	1
00-2241-006-00	Cortical Nut Screwdriver	1
00-2241-008-37	3.7mm Drill Bushing	2
00-2241-008-50	5.0mm Drill Bushing	2
00-2258-067-00	<i>ITST</i> Threaded Guide Pin 355mm	3
00-2255-001-00	Locking Bolt	2
00-2255-004-80	8.0mm Screw Bushing	2
00-2255-028-00	Pin Wrench	1
00-2255-031-37	3.7mm Drill	1
00-2255-035-50	5.0mm Drill, Large	1
00-2255-059-00	Nail Cap Inserter (captured screwdriver)	1

General Instrument Set

Set Number 00-2255-000-16 (includes case/tray/lid + instruments)

Case Set Number 00-2237-095-00 (includes trays and lid)

General Instruments (top tray holds the following)

Prod. No.	Description	
00-2237-053-00	Wire Grip T-Handle	1
00-2237-061-00	Long T-Handle Cannulated Awl	1
00-2237-066-00	Short T-Handle Cannulated Awl	1
00-2255-016-00	7mm Angled Femoral Awl*	1
00-2255-034-00	Reduction Finger	1
00-2255-052-00	9mm/14mm Perc. Tapered Reamer	1
00-2255-060-00	8mm Trochanteric Reamer	1
00-2258-067-00	ITST Threaded Guide Pin 355mm	3
00-2255-038-00	T-Handle	1
00-4816-060-00	Ball-Spiked Pusher	1
00-4817-011-00	Shoulder Hook	1

General Instruments (middle tray holds the following)

Prod. No.	Description	
00-2228-097-00	Diameter Gauge	1
00-2237-055-00	Ruler	1
00-2255-057-00	Flexible Reamer Extension	2
00-2305-024-00	Screwdriver, Small Hexhead	1
00-2237-060-00	Slotted Mallet	1
00-2237-062-00	Threaded Driver	1
00-2237-063-00	Screw Depth Gauge, Long	1
00-2255-013-00	Screwdriver 3.5mm Hex, Long	1
00-2255-017-00	Flared Exchange Tube	1
00-2237-064-00	Nail Length Gauge	1
00-2258-057-00	Cannulated Depth Gauge	1

General Instruments (base of case holds the following)

Prod. No.	Description	
00-2255-009-00	Slaphammer	1
00-2255-028-00	Pin Wrench	1
00-2237-065-00	Threaded Extractor (17cm)	1
00-2237-065-01	Threaded Extractor (32cm)	1
00-2255-012-33	3.2mm Trocar	3
00-2255-012-37	3.7mm Trocar	3
00-2255-012-50	5.0mm Trocar	3
00-2255-033-32	3.2mm Drill	3
00-2255-033-37	3.7mm Drill	3
00-2255-033-50	5.0mm Drill	3
00-2255-018-00	Distal Screw Depth Gauge	1
00-2255-013-01	Distal Screwdriver 3.5mm Hex	1
00-2255-015-03	Wand Handle	1
00-2255-015-01	Wand Insert	1
00-2255-015-02	Wand Set Screw	1

* The 7mm Straight Awl (00-2237-001-07) OR the 7mm Angled Femoral Awl (00-2255-016-00) will fit in the case. However, when you order the set number (00-2255-000-16), you will get the Angled Awl.

Pressure Sentinel Intramedullary Reaming System Order Information

Prod. No.	Description
00-2228-000-00	Pressure Sentinel Reamer Full Set Includes the following instruments & case:

00-2228-005-00	5.0mm Flexible Reamer
00-2228-005-05	5.5mm Flexible Reamer
00-2228-006-00	6.0mm Flexible Reamer
00-2228-006-05	6.5mm Flexible Reamer
00-2228-007-00	7.0mm Flexible Reamer
00-2228-007-05	7.5mm Flexible Reamer
00-2228-008-00	8.0mm Flexible Reamer
00-2228-008-05	8.5mm Flexible Reamer
00-2228-009-00	9.0mm Flexible Reamer
00-2228-009-05	9.5mm Flexible Reamer
00-2228-010-00	10.0mm Flexible Reamer
00-2228-010-05	10.5mm Flexible Reamer
00-2228-011-00	11.0mm Flexible Reamer
00-2228-011-05	11.5mm Flexible Reamer
00-2228-012-00	12.0mm Flexible Reamer
00-2228-012-05	12.5mm Flexible Reamer
00-2228-013-00	13.0mm Flexible Reamer
00-2228-013-05	13.5mm Flexible Reamer
00-2228-014-00	14.0mm Flexible Reamer
00-2228-014-05	14.5mm Flexible Reamer
00-2228-015-00	15.0mm Flexible Reamer
00-2228-015-05	15.5mm Flexible Reamer
00-2228-016-00	16.0mm Flexible Reamer
00-2228-016-05	16.5mm Flexible Reamer
00-2228-017-00	17.0mm Flexible Reamer

00-2228-017-05	17.5mm Flexible Reamer
00-2228-018-00	18.0mm Flexible Reamer
00-2228-018-05	18.5mm Flexible Reamer
00-2228-019-00	19.0mm Flexible Reamer
00-2228-019-05	19.5mm Flexible Reamer
00-2228-020-00	20.0mm Flexible Reamer
00-2228-020-05	20.5mm Flexible Reamer
00-2228-021-00	21.0mm Flexible Reamer
00-2228-021-05	21.5mm Flexible Reamer
00-2228-022-00	22.0mm Flexible Reamer
00-2228-030-00	T-Handle Extractor
00-2228-097-00	Diameter Gauge
00-2228-098-00	Soak Tray
00-5044-012-00	1/4in. Jacob's Chuck to Zimmer Adapter, Qty=2
00-2228-090-00	Sterilization Case

Optional Reamer Sizes

Prod. No.	Description
00-2228-022-05	22.5mm Flexible Reamer
00-2228-023-00	23.0mm Flexible Reamer
00-2228-023-05	23.5mm Flexible Reamer
00-2228-024-01	24.0mm Flexible Reamer
00-2228-024-05	24.5mm Flexible Reamer
00-2228-025-01	25.0mm Flexible Reamer
00-2228-025-05	25.5mm Flexible Reamer
00-2228-026-01	26.0mm Flexible Reamer
00-2228-026-05	26.5mm Flexible Reamer
00-2228-027-01	27.0mm Flexible Reamer

Pressure Sentinel Sets

Prod. No.	Description
00-2228-000-01	Pressure Sentinel Reamer Trauma Set Includes the following instruments & case: 5.0mm, 6.0mm, 7.0mm & 8.00mm-17.5mm Flexible Reamers in .5mm increments (1ea.)
00-2228-030-00	T-Handle Extractor
00-5044-012-00	1/4in. Jacob's Chuck to Zimmer Adapter, Qty=2
00-2228-090-00	Sterilization Case
00-2228-000-02	Pressure Sentinel Reamer Hip Set Includes the following instruments & case: 8.0mm-18.0mm Flexible reamers in 1mm increments (1ea.)
00-2228-030-00	T-Handle Extractor
00-5044-012-00	1/4in. Jacob's Chuck to Zimmer Adapter, Qty=1
00-2228-090-00	Sterilization Case
00-2228-000-03	Pressure Sentinel Reamer Expanded Hip Set Includes the following instruments & case: 8.0mm-18.0mm Flexible reamers in .5mm increments (1ea.)
00-2228-030-00	T-Handle Extractor
00-5044-012-00	1/4in. Jacob's Chuck to Zimmer Adapter, Qty=1
00-2228-090-00	Sterilization case

00-2228-90-00 Sterilization Case

Includes the following components:

00-2228-091-00	Base
00-2228-092-00	18.0mm to 22.0mm Reamer Tray
00-2228-093-00	12.0mm to 17.5mm Reamer Tray
00-2228-094-00	5.0mm to 11.5mm Reamer Tray
00-2228-096-00	Case Lid

00-9975-011-00 Pressure Sentinel Reamer ZMR® Hip Set

Includes the following components:

8.0mm-27.0mm Flexible reamers in .5mm increments (1ea.)	
00-9965-081-10	ZMR Flexible Reamer Diameter Gauge
00-9975-099-00	Case Lid
00-2228-040-00	ZMR Flexible Reamer Metal Case

* Set includes case and contents without the 00-9975-099-00 Case Lid. The Case Lid must be ordered separately.

Optional Instruments

Prod. No.	Description
00-2255-008-00	Guide Wire 2.4mm, Ball-Tip, 70cm box (required for 5.0mm-7.5mm Pressure Sentinel Reamers)
47-2255-008-01	Guide Wire 3.0mm, Ball-Tip, 100cm Sterile/box (required for 8.0mm and larger Pressure Sentinel Reamers)
00-2255-008-01	Guide Wire 3.0mm, Ball-Tip, 100cm Non-sterile/box (required for 8.0mm and larger Pressure Sentinel Reamers)

This documentation is intended exclusively for physicians and is not intended for laypersons. Information on the products and procedures contained in this document is of a general nature and does not represent and does not constitute medical advice or recommendations. Because this information does not purport to constitute any diagnostic or therapeutic statement with regard to any individual medical case, each patient must be examined and advised individually, and this document does not replace the need for such examination and/or advice in whole or in part. Please refer to the package inserts for important product information, including, but not limited to, contraindications, warnings, precautions and adverse effect.



Contact your Zimmer representative or visit us at www.zimmer.com

The CE mark is valid only if it is also printed on the product label.

